

VIBRATIONS, WAVES AND OPTICS EXPERIMENT

MEASURING THE SPEED OF LIGHT

Introduction

In principle, by measuring the time difference τ between a transmitted and received optical signal, the speed of light can be calculated as

$$c = x/\tau$$

where x is the separation between receiver and transmitter. τ could be measured on a CRO, and the signal would be sinusoidally modulated in order to give a continuous display (see Fig. 1).

The time difference τ_0 for the electrical signals to go from the transmitter and receiver to the CRO must be taken into account. τ_0 can, of course, be measured by placing the receiver next to the transmitter at $x = 0$.

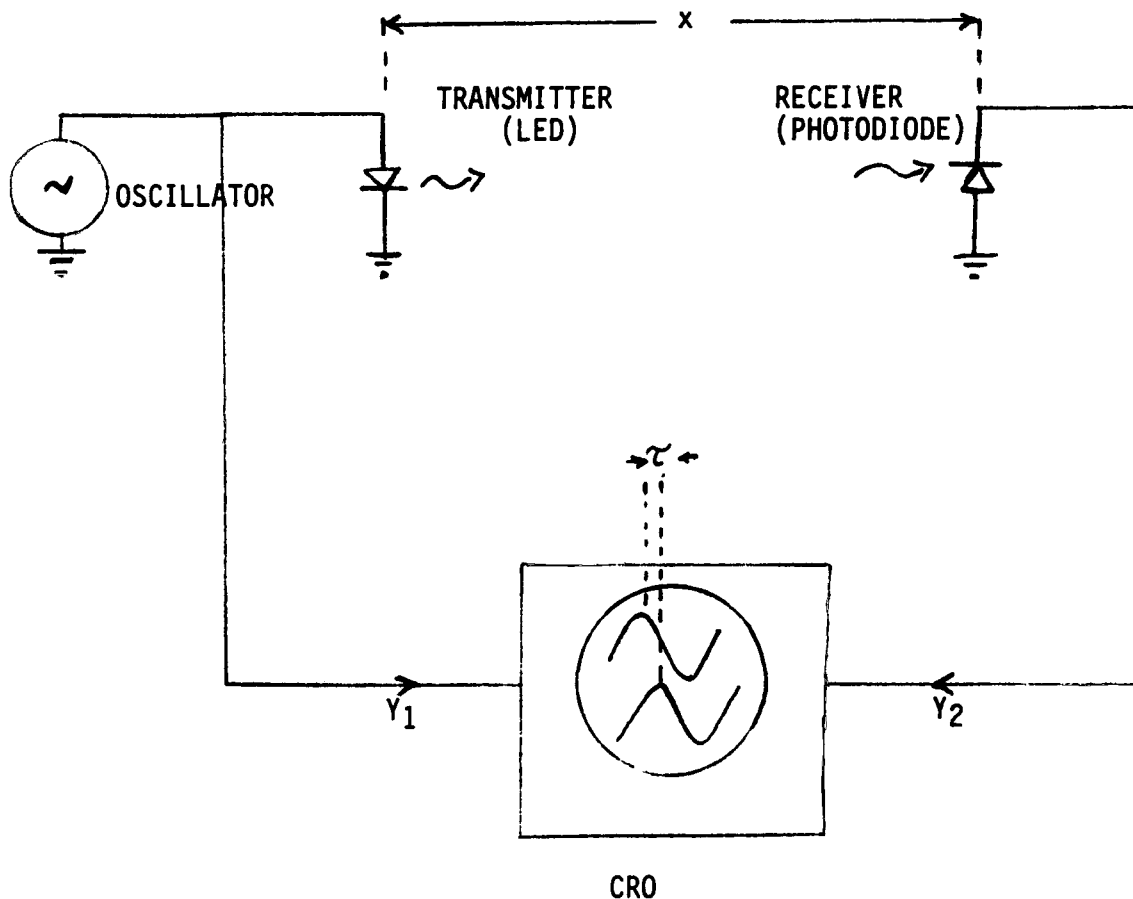

Fig. 1: Simplified version of Speed of Light Apparatus

In practise it is difficult to make the separation x greater than a few metres. Under these conditions τ is, at most a few tens of nanoseconds. Such small time intervals are difficult or impossible to measure on a standard laboratory CRO which has a maximum sweep speed of a few centimetres per microsecond. (At 10cm per μ s sweep, a time delay of 10ns corresponds to 1 mm on the CRO display).

This difficulty can be overcome by mixing (that is multiplying, see appendix) both the transmitted and received signals of frequency ω_1 with a slightly lower frequency ω_2 .

Mixing leads to the appearance of a difference frequency ($\omega_1 - \omega_2$) which can be made quite low if ω_1 and ω_2 are nearly the same value.

As will be shown in the following section, the phase difference ϕ between the received and transmitted signals is unchanged after mixing and hence is much more easily measured at the beat frequency, since it corresponds to a longer time interval, given by $\tau \omega_1 / (\omega_1 - \omega_2)$

Theory

Assume that the transmitted signal is

$$I_t = I_{t0} \cos \omega_1 t$$

and the received signal, time delayed by τ is

$$I_r = I_{r0} \cos \omega_1 (t - \tau)$$

The delay can be expressed in terms of a phase angle ϕ as

$$I_r = I_{r0} \cos (\omega_1 t - \phi) \text{ where } \phi = \omega_1 \tau$$

These signals are fed to the left-hand and right-hand mixers shown in Fig.2 below.

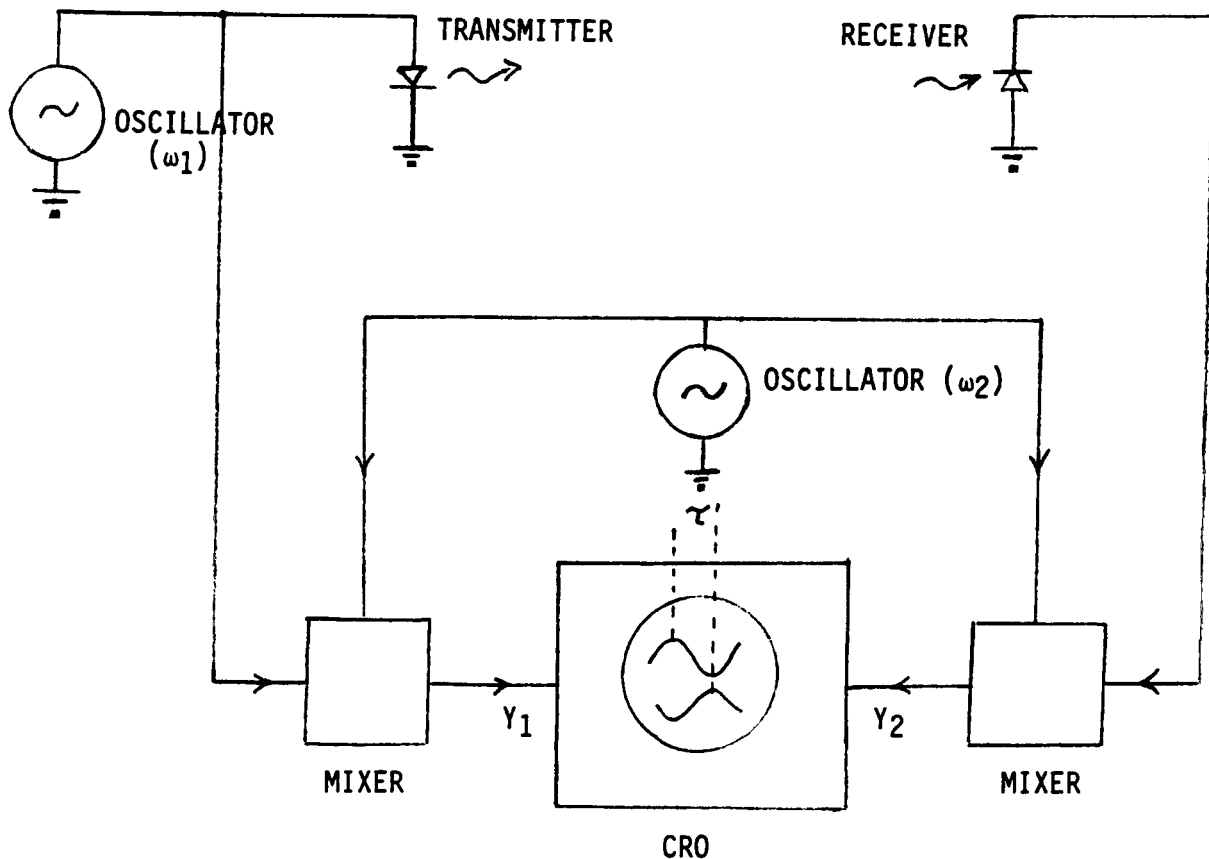

Fig. 2: An improved version of Fig. 1 using mixers to increase the

observed time delay from τ to τ^1 .

The mixer multiplies the two inputs together to give, for the left hand mixer, a signal proportional to $\cos \omega_1 t \cdot \cos \omega_2 t$. This function is equal to $\frac{1}{2} [\cos(\omega_1 + \omega_2)t + \cos(\omega_1 - \omega_2)t]$. A low pass filter removes the high frequency term and the mixer output, proportional to $\cos(\omega_1 - \omega_2)t$ is fed into channel 1 of the CRO.

The right hand mixer has inputs $\cos(\omega_1 t - \phi)$ and $\cos \omega_2 t$. Its output is therefore proportional to $\cos[(\omega_1 - \omega_2)t - \phi]$ and is fed into channel 2 of the CRO. Note that the phase difference ϕ between the transmitted and received signals remains the same after mixing. Before mixing, ϕ is associated with a frequency ω_1 and corresponds to a time delay

$$t = \frac{x}{c} = \frac{f}{w_1}$$

After mixing, ϕ is associated with the difference frequency $(\omega_1 - \omega_2)$ and corresponds to a longer delay

$$t' = \frac{f}{w_1 - w_2} = \frac{w_1 t}{w_1 - w_2}$$

By choosing suitable values for ω_1 and ω_2 , τ' can be easily measured and hence τ calculated.

Experiment

Measure the time delay τ' for ten different transmitter/receiver separations x up to the maximum value permitted by the apparatus. The focussing of the transmitted light onto the receiver will need to be adjusted before each measurement. Plot x vs. τ' and hence calculate c , given that the transmitter modulation frequency ω_1 is 60.000 MHz and the mixing frequency ω_2 is 59.900 MHz.

Determine the additional delay when the water filled tube is placed in the beam. Note the length of the tube. Use your result to determine the speed of light in water and the refractive index of water. Before leaving the laboratory check that you do have the results needed for this determination. In your report you are expected to explain carefully how you determined the refractive index.

Appendix

Mixing

Mixing, or multiplication, of two electrical signals occurs whenever the two signals are input to a device having nonlinear characteristics. For example, the current through a forward biased diode can be expressed as

$$I = a_1 v + a_2 v^2 + \dots$$

If the voltage v is the sum of two component waveforms v_1 and v_2 then the current becomes

$$I = a_1 (v_1 + v_2) + a_2 (v_1 + v_2)^2 + \dots$$

which can be rearranged to give

$$I = a_1 (v_1 + v_2) + a_2 v_1^2 + a_2 v_2^2 + 2 a_2 v_1 v_2 + \dots$$

If v_1 and v_2 are sinusoidal waveforms of frequencies $\omega_1 + \omega_2$, the product term v_1, v_2 will contain sum $(\omega_1 + \omega_2)$ and difference $(\omega_1 - \omega_2)$ frequencies. Either of these can be separated from the other terms in the series by suitable filtering.

Modified June 24th 1999.